

ML_IMC3_LUX Integrated Mirror Fronted Cabinet

Material Specifications

- #304 Stainless Steel
- Designer Matte Black Cabinet
- 5mm Safety Glass

Dimensions/Features

- **Cabinet Size:** 859mmH x 865mmW X 125mmD, includes Hand Dryer, Soap Dispenser, and Paper Towel Dispenser

Installation Guidelines

Step 1: Please refer to the architectural drawings for required product placement and height. **UNIT MUST BE ATTACHED TO A SOLID WALL OR IN-WALL SUPPORT.**

Step 2: Locate the x 4 mounting holes on the back of the unit. Based on the installation height required, mark the 4 mounting points on the wall. Please check the mounting hole measurements as slight variations may occur due to manufacturing tolerance.

Step 3: Using a drill, drill x 4 mounting holes in the marked locations on the wall.

Step 4: Drive the x 4 M8 90mm expansion bolts provided into the drilled mounting holes.

Step 5: Open the front of the mirror to approx. 45°. Using 2 people, lift the mirror cabinet and slowly align it with the expansion bolts on the wall.

Step 6: After placing the unit over the expansion bolts, secure the unit with nuts to complete the installation.

Step 7: Attached the power cord to the power supply and test to ensure all function are working correctly.

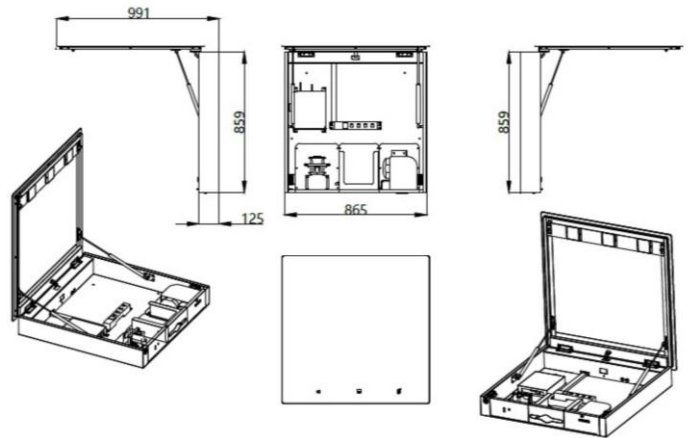

ML_IMC3_LUX

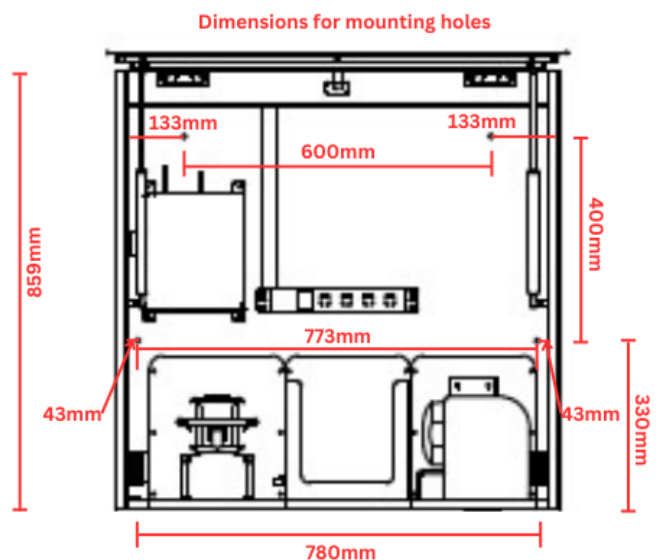

Note

- May be subject to Australian Building Code Regulations for height and location fixing and may be subject to placement as per architectural drawings. In all cases, this is the responsibility of the installer. This product should be installed by a qualified tradesperson.
- This unit is powered by a standard Australian power cable. A power outlet with an isolator switch should be situated within 1 mt above the unit. Please check with an electrician for suitable power supply.
- To ensure the soap dispenser sensor works as intended, install the soap dispenser no less than 200mm from the countertop to the underside of the soap dispenser.
- **Please note mirrors must be inspected within 48 hours of delivery.**

The photographs and line drawings of the products presented above are representational only. Metlam Australia Pty Ltd reserves the right to, and from time to time, make changes and improvements in design and dimensions.

How to adjust the sensor range on the ML_IMC_LUX Integrated Mirror Fronted Cabinet.

Step 1: Use a screwdriver to loosen the cover plate.

Step 2: To increase the sensor range, turn the sensor dial clockwise using a screwdriver. (+) ↻

Step 3: To decrease the sensor range, turn the sensor dial counterclockwise using a screwdriver. (-) ↻

Step 1: Loosen the cover plate



Step 2: Adjusting the sensor



The photographs and line drawings of the products presented above are representational only. Metlam Australia Pty Ltd reserves the right to, and from time to time, make changes and improvements in design and dimensions.